



# BCT613

## 3:1 MIPI D-PHY (3.0 Gbps) 2-Data Lane Switch

# BCT613

## 3:1 MIPI D-PHY (3.0 Gbps) 2-Data Lane Switch

### GENERAL DESCRIPTION

The BCT613 is a 6-Channel single-pole triple-throw (SP3T) switch. BCT613 is optimized for high speed MIPI applications. The BCT613 is designed for two-data lane MIPI D-PHY specification, also can be configured as two-data-lane MIPI C-PHY switch.

BCT613 is available in a QFN4x4-32L Package.

### FEATURES

- 6-Channel, SP3T Switch
- Signal Type: MIPI, D-PHY/C-PHY
- Wide VCC Operating Range: 1.5V~5.0V
- Differential Bandwidth: 3.0 GHz Typical
- $R_{ON}$ : 7.0 $\Omega$
- QFN4x4-32L Package

### APPLICATIONS

- IPC
- Cellular Phones, Smart Phones
- Displays

### ORDERING INFORMATION(QFN4x4-32L)

| Order Number | Package Type | Temperature Range | Marking   | QTY/Reel |
|--------------|--------------|-------------------|---|----------|
| BCT613EGJ-TR | QFN4x4-32L   | -40°C to +85°C    | <br>WQD<br>XXXXX | 5000     |

Note:

1."XXXXX" in Marking will be appeared as the batch code.

### PIN CONFIGURATION (Top View)

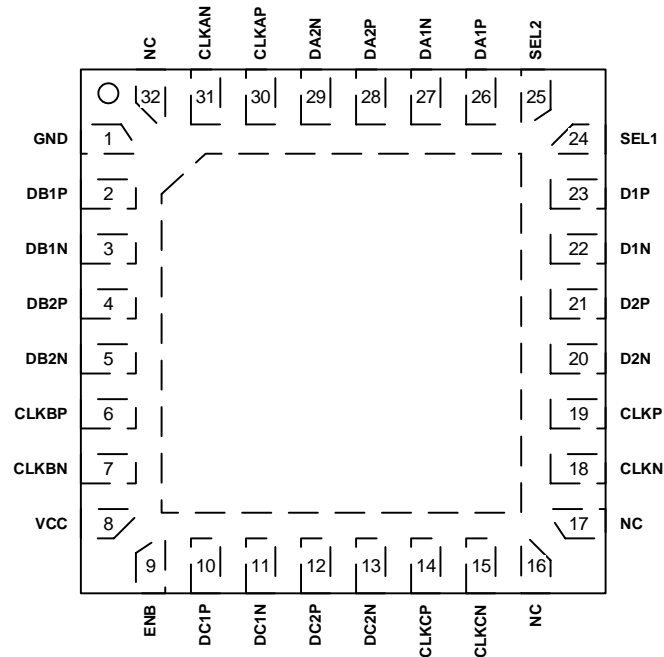

### PIN DESCRIPTION

| Pin   | Name        | Description                | Pin      | Name        | Description          |
|-------|-------------|----------------------------|----------|-------------|----------------------|
| 1     | GND         | Ground                     | 19,18    | CLKP,CLKN   | Clock Path (Common)  |
| 2,3   | DB1P,DB1N   | Data Path 1 (B1)           | 21,20    | D2P,D2N     | Data Path 2 (Common) |
| 4,5   | DB2P,DB2N   | Data Path 2 (B2)           | 23,22    | D1P,D1N     | Data Path 1 (Common) |
| 6,7   | CLKBP,CLKBN | Clock Path (B)             | 24       | SEL1        | Switch Select 1      |
| 8     | VCC         | Device Power               | 25       | SEL2        | Switch Select 2      |
| 9     | ENB         | Output Enable (Active Low) | 26,27    | DA1P,DA1N   | Data Path 1 (A1)     |
| 10,11 | DC1P,DC1N   | Data Path 1 (C1)           | 28,29    | DA2P,DA2N   | Data Path 2 (A2)     |
| 12,13 | DC2P,DC2N   | Data Path 2 (C2)           | 30,31    | CLKAP,CLKAN | Clock Path (A)       |
| 14,15 | CLKCP,CLKCN | Clock Path (C)             | 16,17,32 | NC          | No Connect (Float)   |

### BLOCK DIAGRAM

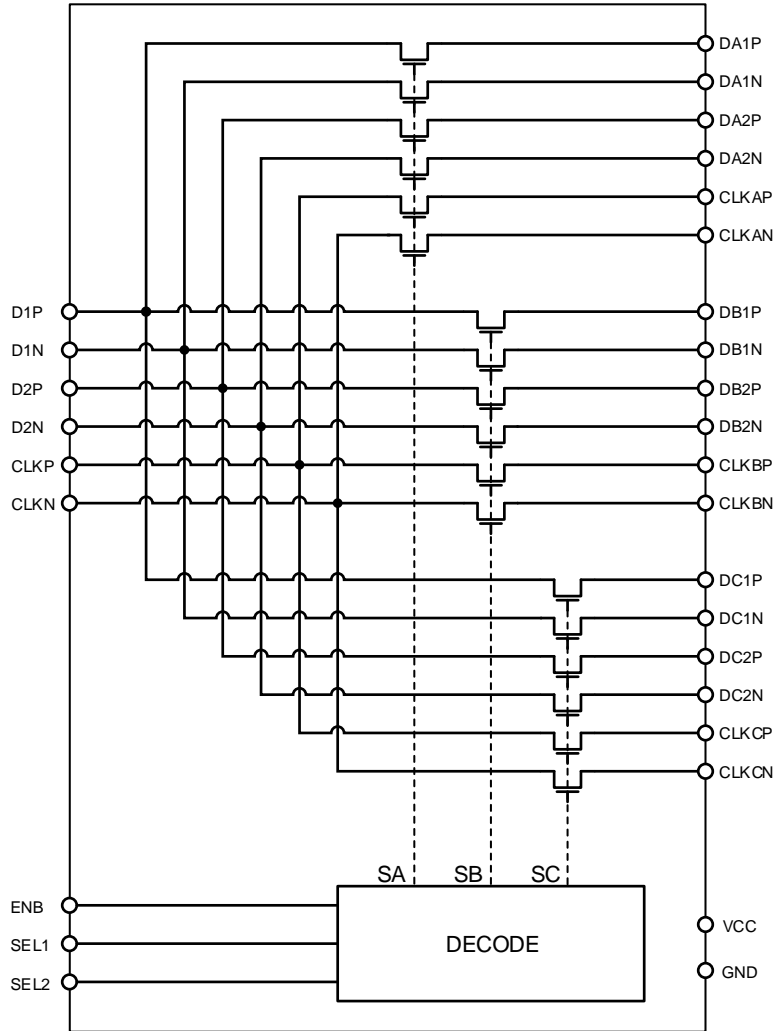

### TRUTH TABLE

| SEL2 | SEL1 | Function                   |
|------|------|----------------------------|
| LOW  | LOW  | D1, D2, CLK=DA1, DA2, CLKA |
| LOW  | HIGH | D1, D2, CLK=DB1, DB2, CLKB |
| HIGH | LOW  | D1, D2, CLK=DC1, DC2, CLKC |
| HIGH | HIGH | Disconnect                 |

### TYPICAL OPERATING CIRCUIT

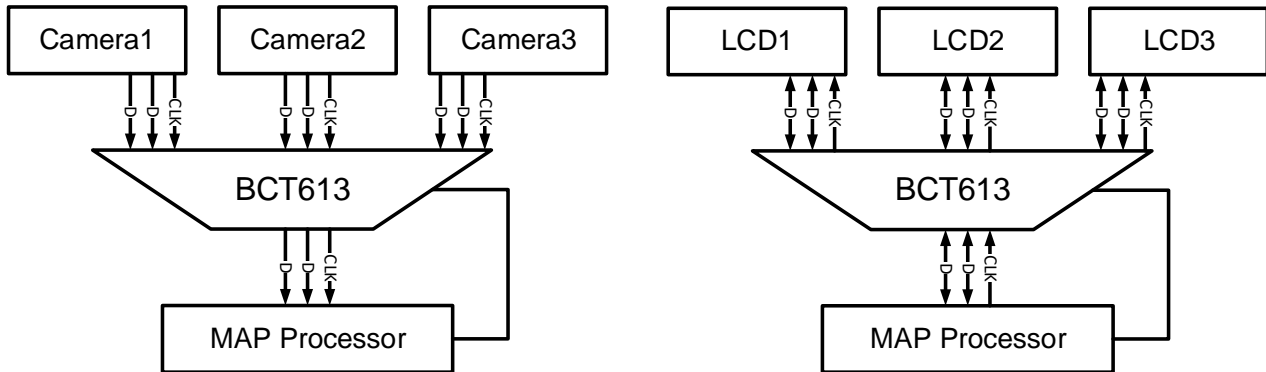

### ABSOLUTE MAXIMUM RATINGS

|  |                 |
|--|-----------------|
| Storage Temperature .....                | -65°C to +150°C |
| Supply Voltage to Ground Potential ..... | -0.5V to +6.0V  |
| DC Input Voltage (SEL1&SEL2&ENB) .....   | -0.5V to +VCC   |
| DC Switch I/O Voltage.....               | -0.3V to 2.2V   |
| DC Output Current .....                  | 25mA            |
| DC Input Diode Current.....              | -50mA           |
| ESD Susceptibility                       |                 |
| HBM All Pins.....                        | 2kV             |

**Note:**

Stresses beyond those listed under “Absolute Maximum Ratings” may cause permanent damage to the device. These are stress ratings only and functional operation of the device at these or any other conditions beyond those indicated in the operational sections of the specifications is not implied. Exposure to absolute Maximum rating conditions for extended periods may affect device reliability.

### RECOMMENDED OPERATING CONDITONS

The Recommended Operating Conditions table defines the conditions for actual device operation. Recommended operating conditions are specified to ensure optimal performance to the datasheet specifications.

| Symbol            | Parameter                             | Min. | Max. | Unit |
|-------------------|---------------------------------------|------|------|------|
| VCC               | Supply Voltage                        | 1.5  | 5.0  | V    |
| V <sub>CTRL</sub> | Control Input Voltage(SEL1,SEL2, ENB) | 0    | VCC  | V    |
| V <sub>SW</sub>   | Switch I/O Voltage                    | 0    | 2.0  | V    |
| T <sub>A</sub>    | Operating Temperature                 | -40  | +85  | °C   |

**Notes:**

- 1.The input and output negative ratings maybe exceed if the input and output diode current ratings are observed.
- 2.The control input must be held HIGH or LOW; it must not float.



# BCT613

## 3:1 MIPI D-PHY (3.0 Gbps)

### 2-Data Lane Switch

## ELECTRICAL CHARACTERISTICS

| Parameter   |                                     | Test Conditions  | Min.         | Typ. | Max. | Units |
|---|-------------------------------------|--|--------------|------|------|-------|
| <b>Power Supply Characteristics</b>                                     |                                     |  |              |      |      |       |
| I <sub>CC</sub>   | Quiescent Power Supply Current      | VCC = Max., V <sub>IN</sub> = GND or VCC                       |              | 25   | 30   | uA    |
| I <sub>CCZ</sub>  | Quiescent Hi-Z Supply Current       | V <sub>SEL</sub> = 0 or VCC, I <sub>OUT</sub> = 0A, ENB=VCC    |              |      | 1    | uA    |
| I <sub>CCCT</sub>   | Increase in ICC per Control Voltage | VCC=3.3V   |              |      | 10   | uA    |
| <b>DC Electrical Characteristics for Switching over Operating Range</b> |                                     |  |              |      |      |       |
| V <sub>IH</sub>   | Input HIGH Voltage                  | Guaranteed HIGH level  | VCC=1.5~3.6V | 1.0  |      | V     |
|   |                                     |  | VCC=3.6~5.0V | 1.4  |      |       |
| V <sub>IL</sub>   | Input LOW Voltage                   | Guaranteed LOW level   | VCC=1.5~5.0V |      | 0.4  | V     |
| V <sub>IK</sub>   | Clamp Diode Voltage <sup>(1)</sup>  | VCC = Max., I <sub>IN</sub> = -18mA                            | VCC&SEL&ENB  |      | -0.7 | V     |
|   |                                     |  | Switch I/O   |      | -1.2 |       |
| I <sub>IH</sub>   | Input HIGH Current                  | VCC =Max., V <sub>IN</sub> = VCC                               | -1           |      | 1    | uA    |
| I <sub>IL</sub>   | Input LOW Current                   | VCC =Max., V <sub>IN</sub> = GND                               | -1           |      | 1    | uA    |
| R <sub>ON</sub>   | Output ON resistance                | VCC =1.8V; 0 V ≤ V <sub>SW</sub> ≤ 2.0V; I <sub>O</sub> = -8mA |              | 7.0  | 10.0 | Ω     |
| ΔR <sub>ON</sub>  | ON-resistance match                 | VCC =1.8V; 0 V ≤ V <sub>SW</sub> ≤ 2.0V; I <sub>O</sub> = -8mA |              | 1.0  | 2.0  | Ω     |
| R <sub>ON_FLAT</sub>  | ON-resistance flatness              | VCC =1.8V; 0 V ≤ V <sub>SW</sub> ≤ 2.0V; I <sub>O</sub> = -8mA |              |      | 2.0  | Ω     |



# BCT613

## 3:1 MIPI D-PHY (3.0 Gbps)

### 2-Data Lane Switch

#### ELECTRICAL CHARACTERISTICS(Continued)

| Parameter  | Test Conditions  | Min.  | Typ. | Max. | Units |     |
|--|--|---|------|------|-------|-----|
| <b>Switching Characteristics</b>                                   |  |   |      |      |       |     |
| t <sub>EN</sub>  | Enable Turn-On Time, ENB to Output                               | R <sub>L</sub> =50Ω, C <sub>L</sub> =5pF, V <sub>SW</sub> =1.2V, VCC=1.5V to 5.0V |      | 50   | 100   | us  |
| t <sub>DIS</sub>   | Disable Turn-off Time, ENB to Output                             | R <sub>L</sub> =50Ω, C <sub>L</sub> =5pF, V <sub>SW</sub> =1.2V, VCC=1.5V to 5.0V |      | 0.1  | 0.3   | us  |
| t <sub>ON</sub>  | Turn-On Time SEL to Output                                       | R <sub>L</sub> =50Ω, C <sub>L</sub> =5pF, V <sub>SW</sub> =1.2V, VCC=1.5V to 5.0V |      | 0.1  | 1.25  | us  |
| t <sub>OFF</sub>   | Turn-Off Time SEL to Output                                      | R <sub>L</sub> =50Ω, C <sub>L</sub> =5pF, V <sub>SW</sub> =1.2V, VCC=1.5V to 5.0V |      | 0.1  | 1.15  | us  |
| t <sub>b-b</sub>   | Bit-to-Bit skew within the same differential pair <sup>(1)</sup> |   |      | 7    |       | ps  |
| t <sub>ch-ch</sub>   | Channel-to-Channel skew <sup>(1)</sup>                           |   |      | 35   |       | ps  |
| <b>Dynamic Electrical Characteristics over the Operating Range</b> |  |   |      |      |       |     |
| X <sub>TALK</sub>  | Differential Crosstalk <sup>(1)</sup>                            | f = 1.5 GHz   |      | -40  |       | dB  |
| O <sub>IRR</sub>   | Differential OFF Isolation <sup>(1)</sup>                        | f = 1.5 GHz   |      | -25  |       | dB  |
| I <sub>LOSS</sub>  | Differential Insertion Loss <sup>(1)</sup>                       | f = 1.5 GHz   |      | -1.2 |       | dB  |
| BW   | Differential Bandwidth -3dB <sup>(1)</sup>                       |   |      | 3.0  |       | GHz |

Notes:

1. Guaranteed by design.

## TYPICAL PERFORMANCE CHARACTERISTICS

Test condition:  $T_A=25^{\circ}\text{C}$ ,  $V_{CC}=1.8\text{V}$ , Differential Mode (unless otherwise noted)

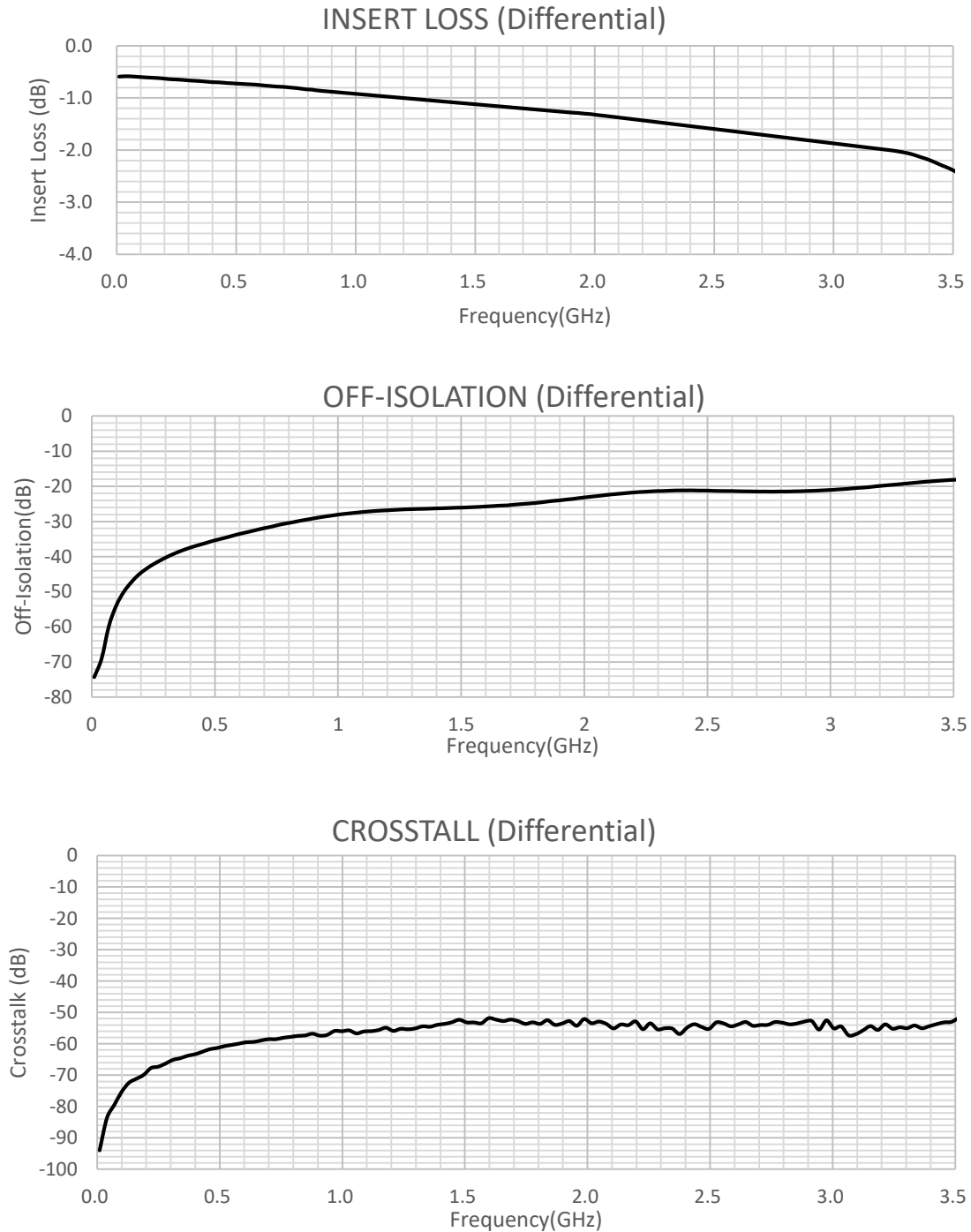

### PACKAGE OUTLINE DIMENSIONS

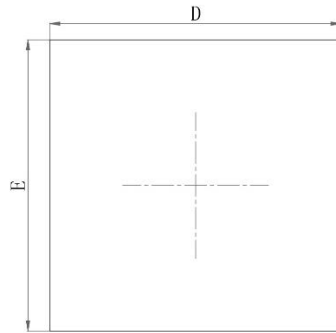

TOP VIEW  
[顶视图]

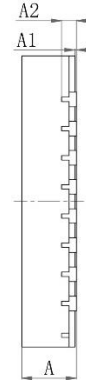

SIDE VIEW  
[侧视图]

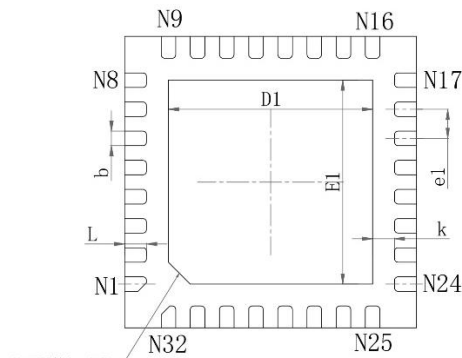

PIN#1 ID  
0.3×45°

BOTTOM VIEW  
[背视图]

| Symbol | Dimensions In Millimeters |       |       | Dimensions In Inches |       |       |
|--------|---------------------------|-------|-------|----------------------|-------|-------|
|        | Min.                      | Nor.  | Max.  | Min.                 | Nor.  | Max.  |
| A      | 0.700                     | 0.750 | 0.800 | 0.028                | 0.030 | 0.031 |
| A1     | 0.000                     | -     | 0.050 | 0.000                | -     | 0.002 |
| A2     | 0.203REF.                 |       |       | 0.008REF.            |       |       |
| D      | 3.900                     | 4.000 | 4.100 | 0.154                | 0.157 | 0.161 |
| E      | 3.900                     | 4.000 | 4.100 | 0.154                | 0.157 | 0.161 |
| D1     | 2.700                     | 2.800 | 2.900 | 0.106                | 0.110 | 0.114 |
| E1     | 2.700                     | 2.800 | 2.900 | 0.106                | 0.110 | 0.114 |
| b      | 0.150                     | 0.200 | 0.250 | 0.006                | 0.008 | 0.010 |
| e1     | 0.400BSC.                 |       |       | 0.016BSC.            |       |       |
| k      | 0.300REF.                 |       |       | 0.012REF.            |       |       |
| L      | 0.200                     | 0.300 | 0.400 | 0.008                | 0.012 | 0.016 |